

PRECISION FORMED PLASTICS

Pattern W605 Oliver

Wood design – heavy grain boards
joined with tight seams

High Impact Styrene - Single Use

ABS Plastic- Up to 8 uses

Sheet Size 48"x144"

Maximum Relief 1/8" Board

Widths 3"

Mating - Side to Side only

148"



48"

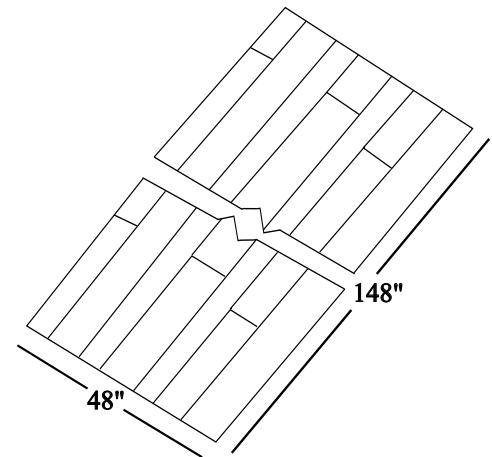
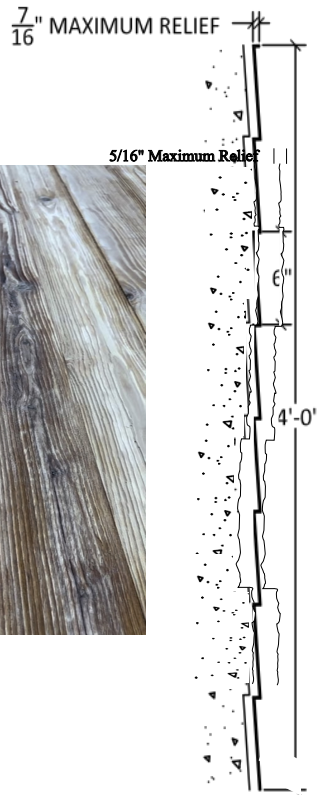

Precision Edge TM

Thicknesses Available:

0.060", 0.090", 0.110"

- Keep out of direct sunlight
- Cover when not in use
- Store at temperature range of 55°-85° F
- Do not expose to temperatures in excess of 140° F
- Formliner may require backing
- Thermal expansion or contraction of approximately 1/16" per 10° F temperature change can occur

PRECISION FORMED PLASTICS, LLC

748 South Meadows Parkway, Suite A9-354

Reno, Nevada 89521

775-484-1155

www.precisionformedplastics.com